



# XR 230 SPOT

PR-2200

This product manual contains important information about the safe installation and use of this projector. Please read and follow these instructions carefully and keep this manual in a safe place for future reference.

PR LIGHTING LTD.  
<http://www.pr-lighting.com>

## INDEX

SAFE USAGE OF THE PROJECTOR	3
INSTALLING THE PROJECTOR	4
FITTING THE LAMP	4
POWER SUPPLY – MAINS	5
CONTROL CONNECTIONS	5
DMX TERMINATOR	6
SETUP OPTIONS-PROJECTOR CONFIGURATION	6
TO SET THE DMX START ADDRESS	6
STAND-ALONE MODE	7
MASTER/SLAVE MODES	7
OPERATION MENU	7
ERROR MESSAGE	11
REPLACING GOBOS	13
DMX PROTOCOL	13
MAINTENANCE	16
LUBRICATION	16
KEEPING THE PROJECTOR CLEAN	17
TROUBLESHOOTING	17
TECHNICAL DATA	18
ELECTRICAL DIAGRAM	21
COMPONENT ORDER CODES	22

Please note that as part of our ongoing commitment to continuous product development, specifications are subject to change without notice. Whilst every care is taken in the preparation of this manual we reserve the right to change specifications in the course of product improvement. The publishers cannot be held responsible for the accuracy of the information herein, or any consequence arising from them.

Every unit is tested completely and packed properly by the manufacturer. Please make sure the packing and / or the unit are in good condition before installation and use. Should there be any damage caused by transportation, consult your dealer and do not use the unit. Any damage caused by improper use will not be assumed by the manufacturer and / or dealer.

## ACCESSORIES

These items are packed together with the projector:

Name	Quantity	Unit	Remark
G clamps	2	Pcs	
XLR connector	1	Set	Without cable
Power Con	1	Set	With cable
Safety cord	1	Pc	
User's manual	1	Pc	
Ω clamps	2	Pcs	Optional

## SAFE USAGE OF THE PROJECTOR

When unpacking and before disposing of the carton check there is no transportation damage before using the projector. Should there be any damage caused by transportation, consult your dealer and do not use the apparatus.

The projector is for indoor use only, IP20. Use only in dry locations. Keep this device away from rain and moisture, excessive heat, humidity and dust. Do not allow contact with water or any other liquids.

The projector is not designed or intended to be mounted directly on to inflammable surfaces.



The projector is only intended for installation, operation and maintenance by qualified personnel.

The projector must be installed in a location with adequate ventilation, at least 50cm from adjacent wall surfaces. Be sure that no ventilation slots are blocked.

Do not project the beam onto inflammable surfaces, minimum distance is 3m.

Avoid direct exposure to the light from the lamp. The light is harmful to the eye.

Do not attempt to dismantle and/or modify the projector in any way.

Electrical connection must only be carried out by qualified personnel.

Before installation, ensure that the voltage and frequency of power supply match the power requirements of the projector.

It is essential that each projector is correctly earthed and that electrical installation conforms to all relevant standards.

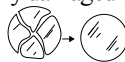
Do not connect this device to any other types of dimmer apparatus.

Make sure that the power-cord is never crimped or damaged by sharp edges. Never let the power-cord come into contact with other cables. Only handle the power-cord by the plug. Never pull out the plug by tugging the power-cord.

Keep the lamp clean. Do not touch the lamp glass with bare hand.

The projector should always be installed with a secondary safety fixing. A safety cord is supplied for this; it should be attached as shown in "installing the projector" section.

Shields and lens shall be changed if they have become visibly damaged to such an extent that their effectiveness is impaired, for example by cracks or deep scratches.



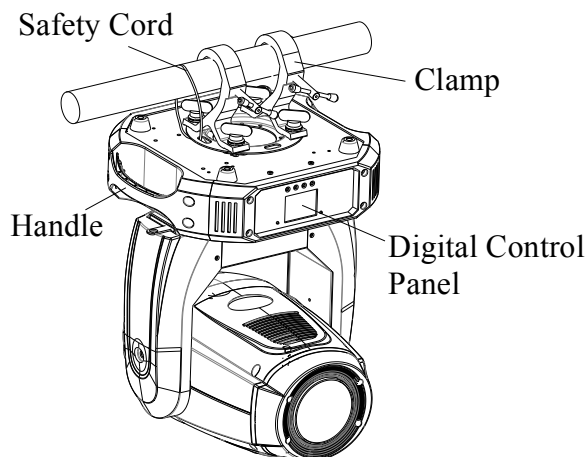
Exterior surface temperatures of the luminaire after 30 minutes operation is 45°C, when steady state is achieved 60°C,

There is no user serviceable parts inside the projector, do not open the housing and never operate the projector with the covers removed.

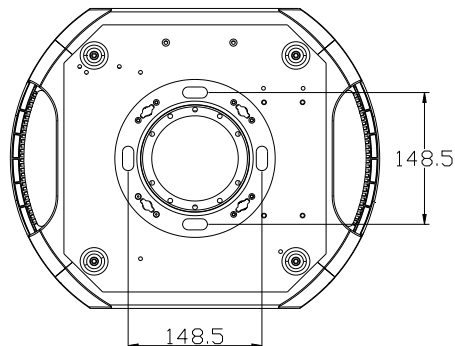
If you have any questions or suggestions, don't hesitate to consult your dealer or manufacturer

**Always disconnection from Power, when the device not in use or before cleaning or any maintenance work !**

## INSTALL THE PROJECTOR



**Warning**  
Please run the safety cord through two holes for safety.



Take 2 clamps and the safety cord out from the package and mount 2 clamps on the underside of fixture with 2 retainers attached to each clamp. Hang the fixture on the structure and fasten the screws attached to each clamp. (See the **WARNING** on the underside of the base as shown above) **To pass the SAFETY CORD through the HOLES for safety!** Always ensure that the projector is firmly anchored to avoid vibration and slipping whilst functioning. Always ensure that the structure that you are going to mount the projector to is secure and strong enough to support the weight of a XR 330 Spot

**WARNING:**

1. The projector **MUST** be lifted or carried by the **HANDLES** instead of clamps.
2. For safety the safety cord should afford 10 times the Projector's weight.

## FITTING THE LAMP

Lock the yoke before fitting/replacing /adjusting the lam just as Shown by Figure 1, after Opening the cover at the rear of the projector by loosening 8fastfit screws at both sides of the head.

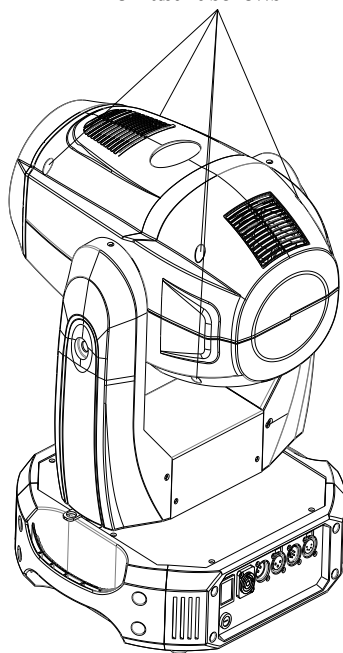
For lamp adjustment, please see the figure2. The removal of a lamp is showed by the figure3. Please tighten the power cord for the lamp before the installation.

Installation and removal are in reverse orders.

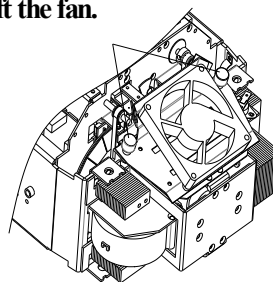
**Note: don't touch the bulb of the new lamp with bare hands so as not to impair the beam output. Do not damage the sticking-out of the lamp.**

**Important: Always read "Instructions for use" enclosed with the lamp.**

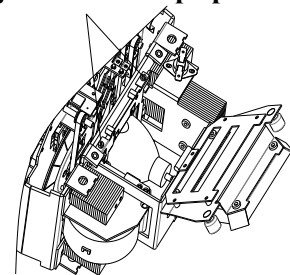
**Figure 1: 8 pcs of fastfit screws**



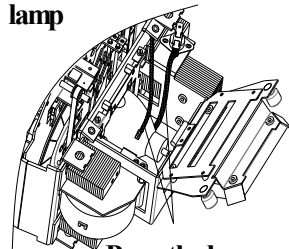
**Figure2:Lamp adjustment /loosen the two screws and lift the fan.**



**Using cross screwdriver to adjust the two screws for the adjustment the lamp's position**

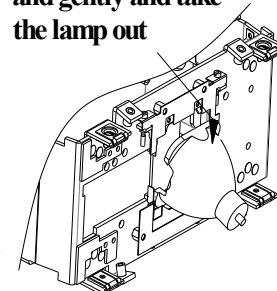


**Figure3:Take out the lamp**



**Press the lamp aslant**

**and gently and take the lamp out**



## POWER SUPPLY-MAINS

Connect the power cord as follows:

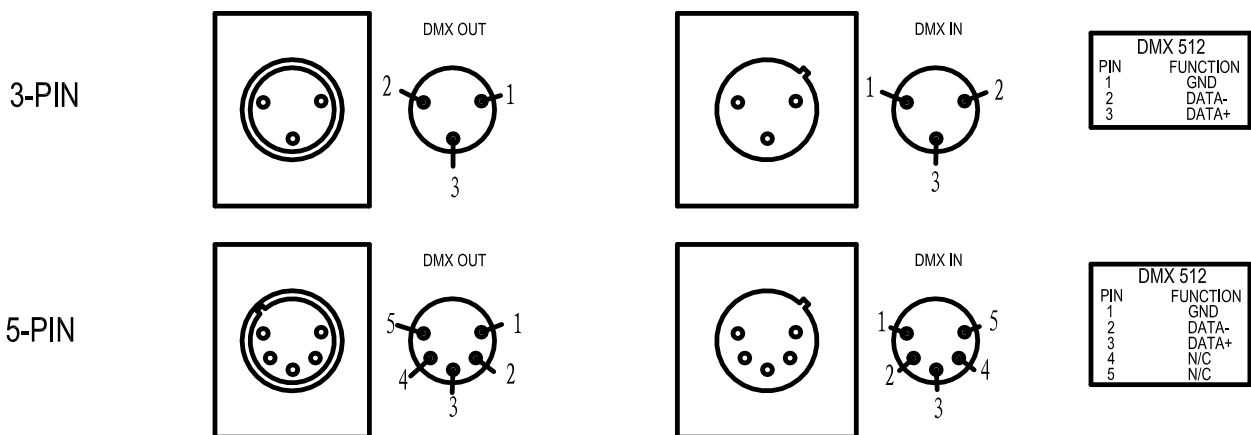
- L (live) =brown
- E (earth) =yellow/green
- N (neutral) =blue

Before connection with mains power, make sure that the voltage and frequency marked on the rating plate of the projector match what are supplied. It is recommended that each projector be supplied separately so that they may be individually switched on and off.

**IMPORTANT:**

**It is essential that each projector is correctly earthed (yellow/green twin wire) and the electrical installation conforms to all relevant standards.**

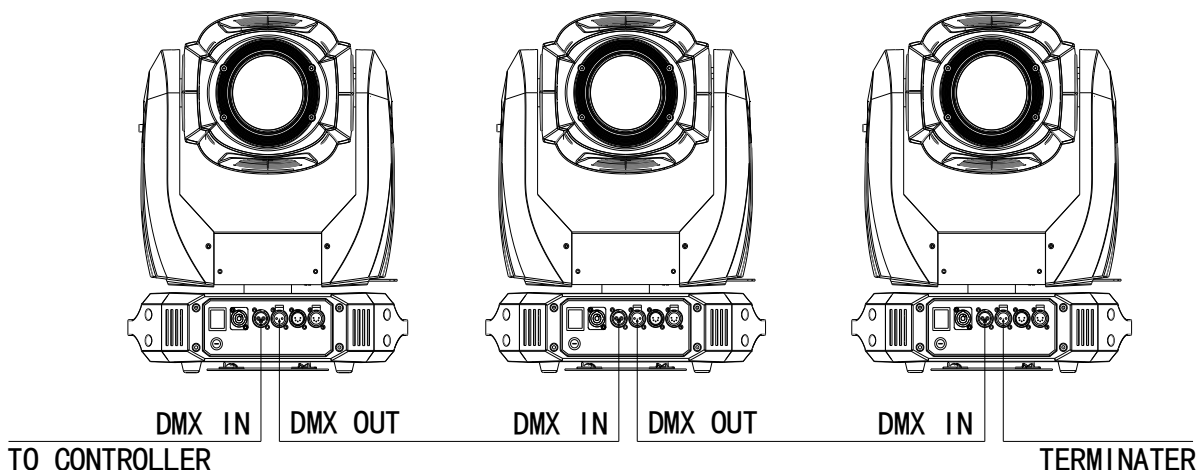
## CONTROL CONNECTION



Connection between controller and projector and between one projector and another must be made with a twin-screened cable, with each wire having at least a 0.5mm in diameter. Connection to and from the projector is via cannon 5 pin (which are included with the projector) or 5 pin XLR plugs and sockets. The XLR's are connected as shown in the figure above.

Note: care should be taken to ensure that none of the pins touch the metallic body of the plug or each other. XLR plugs and sockets mustn't be connected in any way other than mentioned in the above figure. The XR 330 Spot accepts digital control signals in protocol DMX512 (1990).

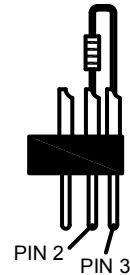
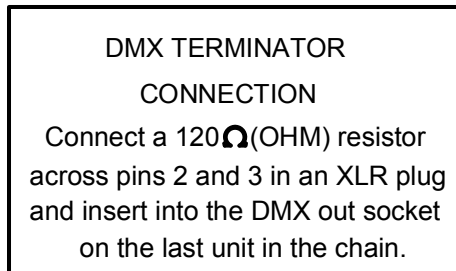
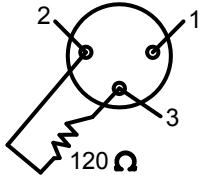
Connect the controller's DMX output to the first fixture's DMX input, and connect the first fixture's DMX output to the second fixture's DMX input and connect the rest fixtures in the same way. Eventually connect the last fixture's DMX output to a DMX terminator as shown in the figure below.



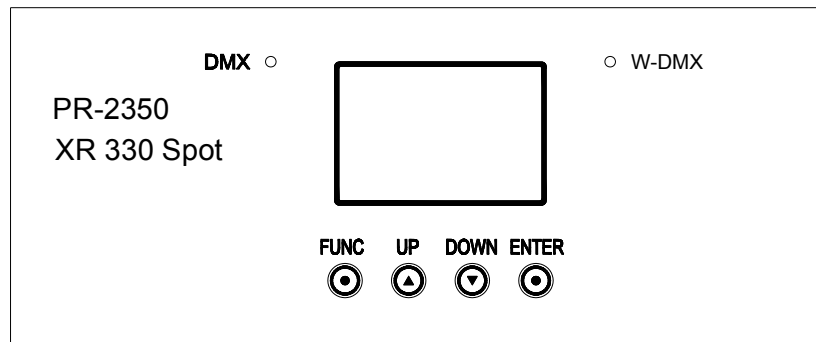
## DMX TERMINATOR

In the Controller mode, at the last fixture in the chain, the DMX output has to be connected with a DMX terminator. This prevents electrical noise from disturbing and corrupting the DMX control signals.

The DMX terminator is simply an XLR connector with a 120Ω (ohm) resistor connected across pins 2 and 3, which is then plugged into the output socket on the last projector in the chain. The connections are illustrated below.



## SETUP OPTIONS-PROJECTOR CONFIGURATION



Projector configuration can be set conveniently via push button and LCD display.

Launch the projector and press button **ENTER** for more than 5 seconds to unlock the panel, the LCD will show the function menu of the projector, each main menu has its submenus and each submenu has a specific function. For details, please see the “OPERATION MENU” section.

Press button **UP** or **DOWN** if you want to browse through the various Setup Options.

Press button **ENTER** to save your settings or enter the submenu.

Press button **UP** or **DOWN** to change values(plus or minus)

Press button **FUNC**, it will return to the upper menu. If button **FUNC** not pressed, the default will show display status automatically.

## TO SET THE DMX START ADDRESS

Each XR 330 Spot must be given a DMX start address so that the correct projector responds to the correct control signals. This DMX start address is the channel number from which the projector starts to “listen” to the digital control information being sent out from the controller. The XR 330 Spot has 3 DMX modes. There are standard mode, short mode and extended mode. For example standard mode has 25 channels, so set the No. 1 projector’s address 001, No. 2 projector’s address 026, No. 3 projector’s address 051, and so on.

Launch the projector. Press button **ENTER** more than 5 seconds to unlock panel.

Press button **ENTER** to display DMX address;

Press button **UP** and **DOWN**, you can set the address;

Press button **ENTER** to confirm; after powered on next time, the default will be last value saved

Press button **FUNC**, it will return to the upper menu.

## STAND-ALONE MODE

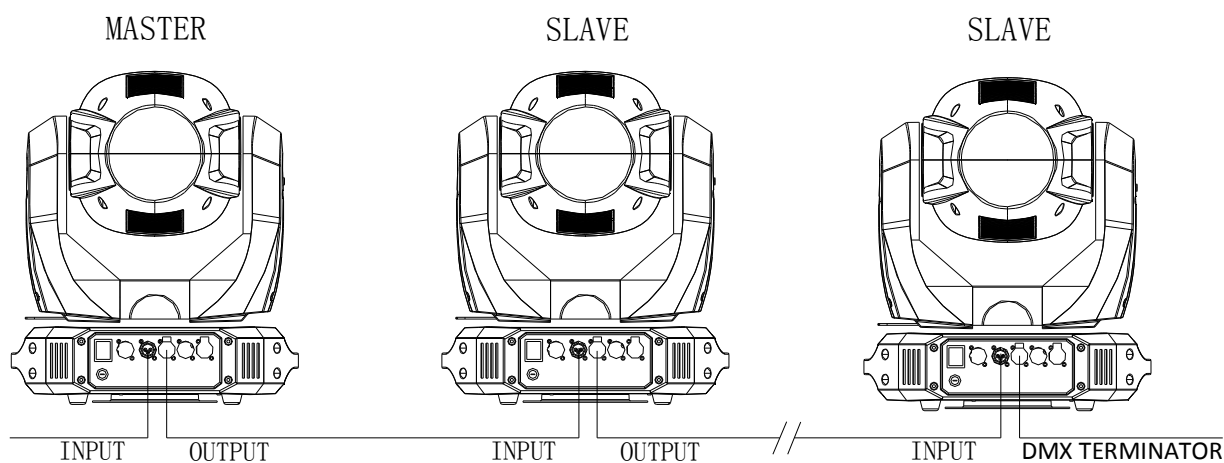
Operate the projector without connecting a controller, enable the master mode in the operation panel, the projector will run in Stand-Alone mode automatically.

## MASTER/SLAVE MODE

Without using a controller, many projectors can run synchronously in the Master/Slave mode by linking them with each other. Connect the controller's output to the first fixture's input, and connect the first fixture's output to the second fixture's input and connect the rest fixtures in the same way. Eventually connect the last fixture's output to a DMX terminator as shown in the figure below. Then the first one is the master with setting options as master mode enabled, and others are slaves.

Start Address for all slaves is 001. The Master can run at any mode for the Master and Slaves run at the corresponding mode compared to the Master.

After switched on, the group will run at Master/Slave Mode.



## OPERATION MENU

First Menu	Secondary Menu	Third Menu	Fourth Menu
DMX Address DMX 地址	XXX (XXX:1~449)		
Reset	Are You Sure		
Config Settings	DMX Mode (Default: Standard)	Standard 16	
		Extended 16	
		Short 8	
	Lamp Control (Default: CHAN)	By Control Channel	
		By Power On	
		By DMX Present	
Loss of DMX	When DMX is Lost Normal Time out		

		When DMX is Lost Hold Last value		
	Fan Operate Mode	Fan Operate Mode Normal (Quieter) (Hot Environment)		
	Factory Settings (Press button DOWN/UP/ENTER at the same time to enter the sub-menu)	Fixture Type (WARNING: Never change the fixture type or the system will be damaged!)		
Option Settings	Color Positions	Color Positions STEPPED		
		Color Positions LINEAR		
	F-Gobo Positions	F-Gobo Positions STEPPED		
		F-Gobo Positions LINEAR		
	Pan DMX Invert	Pan DMX Invert OFF		
		Pan DMX Invert ON		
	Tilt DMX Invert	Tilt DMX Invert OFF		
		Tilt DMX Invert ON		
	Pan Tilt Swap	Pan Tilt Swap OFF		
		Pan Tilt Swap ON		
	Dimmer Invert	Dimmer Invert OFF		
		Dimmer Invert ON		
	Iris Invert	Iris Invert OFF		
		Iris Invert ON		
	Zoom Invert	Zoom Invert OFF		
		Zoom Invert ON		
	CMY Invert	CMY Invert OFF		
		CMY Invert ON		
	Defaults	Defaults OFF		
		Defaults Restore Defaults		
Display Options	Display Mode	Display On Always		
		Display Off After Delay		
	Display Invert	Display Invert OFF		
		Display Invert ON		
	Display Dimming	Disp Dim Level Min		
		Disp Dim Level 1		
		Disp Dim Level 2		
		Disp Dim Level 3		
			Disp Dim Level 4	

	Disp Dim Level 5	
	Disp Dim Level 6	
	Disp Dim Level 7	
	Disp Dim Level 8	
	Disp Dim Level 9	
	Disp Dim Level Full	
Display Contrast	Display Contrast XX(1~21)	
Display Language	Language= English	
	Language= Chinese	
Lamp Hours	Lamp Hours= XX	Reset Lamp Hours Are You Sure(UP/DOWN)
Total Hours	Total Hours= XX	
Temperature	Display Board	Display Board= XX°C
	Driver Board 1	Driver Board 1= XX°C
	Driver Board 2	Driver Board 2= XX°C
	Driver Board 3	Driver Board 3= XX°C
	Pan and Tilt	Pan and Tilt= XX°C
	Head Sensor	Head Sensor= XX°C
Software Version	Display Board	Display Board= X.X.X
	Driver Board 1	Driver Board 1= X.X.X
	Driver Board 2	Driver Board 2= X.X.X
	Driver Board 3	Driver Board 3= X.X.X
	Pan and Tilt	Pan and Tilt= X.X.X
View DMX Values	DMX Channel 1=XXX	
Electronic SN	Electronic SN= *****	
RDM Device Label	RDM Device Label ANSI E1.20 RDM Version X.X	
Pan Encoder	Wiring Normal Pan Err 0 Count 0	
Tilt Encoder	Wiring Normal Tilt Err 0 Count 0	
Driver Faults	X Over Temp 0 Y Over Temp 0	

		X Fault     0 Y Fault     0	
Test Modes	Factory Setup	Factory Setup OFF	
		Factory Setup ON	
	Self Test	Self Test OFF	
		Self Test ON	
Lamp Manual Control	Lamp Status	On Command Sent S=X   C=X Lamp On	
	Turn Lamp On		
	Turn Lamp Off		
Wireless Options	Wireless Mode	Wireless Mode XLR First	
		Wireless Mode XLR Only	
		Wireless Mode Wireless To XLR	
		Wireless Mode Wireless Only	
	Un-Link Wireless	Really Un-Link Enter=Yes	
Lamp Fan Test	Lamp Fan Test Automatic 1		
	Lamp Fan Test 1		
	Lamp Fan Test 2		
	Lamp Fan Test 3		
	Lamp Fan Test 4		
	Lamp Fan Test 5		
	Lamp Fan Test 6		
	Lamp Fan Test 7		
	Lamp Fan Test 8		
	Lamp Fan Test 9		
	Lamp Fan Test 10		
Head Fan Test	Head Fan Test Automatic 1		
	Head Fan Test 1		

	Head Fan Test 2		
	Head Fan Test 3		
	Head Fan Test 4		
	Head Fan Test 5		
	Head Fan Test 6		
	Head Fan Test 7		
	Head Fan Test 8		
	Head Fan Test 9		
	Head Fan Test 10		
Box Fan Test	Box Fan Test 1		
	Box Fan Test 2		
	Box Fan Test 3		
	Box Fan Test 4		
	Box Fan Test 5		
	Box Fan Test 6		
	Box Fan Test 7		
	Box Fan Test 8		
	Box Fan Test 9		

## ERROR MESSAGES

In the course of launch, Projector examines automatically whether there are errors and if there are, it will display information as follows:

Sensor Err	S1-M1	Color wheel (1# drive board motor 1) error
Sensor Err	S1-M2	CTO (1# drive board motor 2) error
Sensor Err	S1-M3	CYM-magenta (1# drive board motor 3) error
Sensor Err	S1-M4	CYM-yellow (1# drive board motor 4) error
Sensor Err	S1-M5	CYM-cyan (1# drive board motor 5) error

Sensor Err S2-M1	Rotating Gobo wheel (2# drive board motor 1) error
Sensor Err S2-M2	Gobo rotation (2# drive board motor 2) error
Sensor Err S2-M3	Effect Wheel (2 drive board motor 3) error
Sensor Err S3-M1	Focus (3# drive board motor 1) error
Sensor Err S3-M2	Zoom(3# drive board motor 2) error
Sensor Err S3-M3	Prism (3# drive board motor 3) error
Sensor Err S3-M4	Prism rotation (3# drive board motor 4) error
Sensor Err S3-M5	Fixed Gobo wheel (3# drive board motor 5) error
Over Temp Error	
Temp Sense Error	
Head Fan 1 Fail	
Head Fan 2 Fail	
Head Fan 3 Fail	
Head Fan 4 Fail	
Pan Encoder Err	
Tilt Encoder Err	
Pan Enc T Out	Pan Auto-Position Overtime
Tilt Enc T Out	Tilt Auto-Position Overtime
Pan Sensor Error	
Tilt Sensor Error	
Pan Over Temp	
Pan Driver Fault	
Tilt Over Temp	
Tilt Driver Fault	
Pan Enc Rev Err	Pan Encoder Reverse Wiring Error
Tilt Enc Rev Err	Tilt Encoder Reverse Wiring Error

**Remark:**

1. In the synchronous control of multiple projectors parameters can be transmitted from the master including: DMX mode, display setting, operation mode(user memory);
2. all projectors Accepting parameters will automatically be set to slave mode.

Signs on top-right of the menu Panel:

S: Slave Status            M: Master Status

D: DMX512 Mode        I: Preset Memory Mode

U: User Memory Mode    T: Test Mode

If Lock logo on, all buttons locked. press "CONFIRM" key more than 3seconds, the lock logo disappears and buttons are unlocked

## REPLACING GOBOS

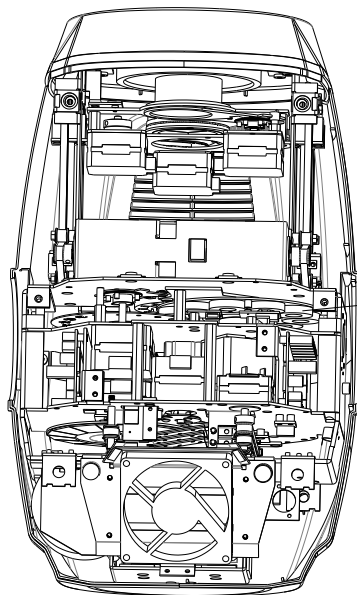


figure 1

Replacement of rotating gobos: disconnect from power, loosen the four fastfit screws of the side cover like figure 1, pull out the rotators by finger as figure 2.

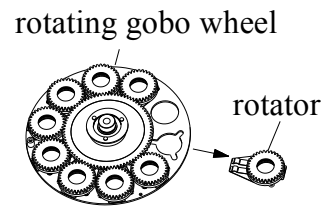
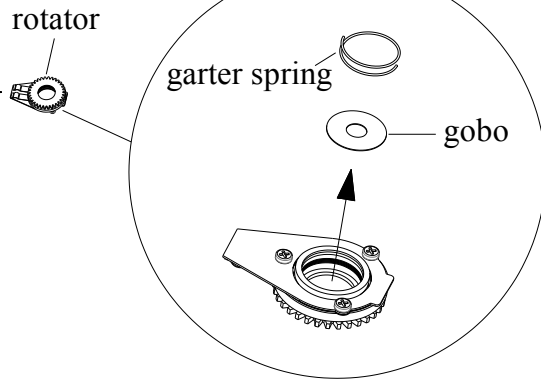


figure 2



rotator

garter spring

gobo

## DMX PROTOCOL

Short mode	Standard mode	Extended Mode	FUNCTION	DMX	DESCRIPTION
1	1	1	Strobe	000-010	Close
				011-025	Open
				026-225	Strobe speed from slow to fast
				226-239	Macro 1
				240-241	Macro 2
				242-246	Macro 3
				247-255	Open
2	2	2	Dimmer	000-003	Close
				004-255	Linear dimming (0-100%)
	3	3	Dimmer Fine	000-255	Dimming in 16 bit
3	4	4	CYM Macro	000-016	White
				017-035	Yellow+ Magenta=Red
				036-054	Yellow
				055-073	Yellow +Cyan=Green
				074-092	Cyan
				093-110	Cyan + Magenta= Violet
				111-128	Magenta
				129-255	CYM color mixing from slow to fast
4	5	5	Cyan	000-255	Cyan (linear 0~100%)
		6	Cyan fine	000-255	Cyan in 16 Bit
5	6	7	Yellow	000-255	Yellow (linear 0~100%)

		8	Yellow fine	000-255	Yellow in 16 Bit
6	7	9	Magenta	000-255	Magenta ( linear 0~100%)
		10	Magenta fine	000-255	Magenta in 16 Bit
7	8	11	Color Wheel	000-008	White
				009-016	Color 1
				017-024	Color 2
				025-032	Color 3
				033-040	Color 4
				041-048	Color 5
				049-056	Color 6
				057-064	Color 7
				065-073	Color 8
				074-082	Color 9
				083-091	Color 10
				092-100	Color 11
				101-109	Color 12
				110-118	Color 13
				119-128	Color 14
129-191	Rotation(Clockwise from slow to fast)				
192-255	Reverse rotation (Anti-clockwise from slow to fast)				
8	9	12	Iris	000-255	From big to small in size
		13	Iris Fine	000-255	Iris in 16 Bit
9	10	14	Iris Macro	000-010	White
				011-072	Iris Effect 1
				073-136	Iris Effect 2
				137-198	Iris Effect 3
				199-214	Iris Effect 4
				215-222	Iris Effect 5
				223-230	Iris Effect 6
				231-255	Fully Open
10	11	15	Fixed Gobo Wheel	000-007	White
				008-014	Gobo 1
				015-021	Gobo 2
				022-028	Gobo 3
				029-035	Gobo 4
				036-042	Gobo 5
				043-049	Gobo 6
				050-056	Gobo 7
				57-63	Gobo 8
				64-70	Gobo 9
				71-77	Gobo 10
				78-84	Gobo 11
85-92	Gobo 12				

				93-99	Gobo 13
				100-106	Gobo 14
				107-113	Gobo 15
				114-120	Gobo 16
				121-127	Gobo 17
				128-146	Rotation (clockwise from slow to fast)
				147-165	Reverse Rotation(anti-clockwise from slow to fast)
				166-170	Shake of Gobo 1
				171-175	Shake of Gobo 2
				176-180	Shake of Gobo 3
				181-185	Shake of Gobo 4
				186-190	Shake of Gobo 5
				191-195	Shake of Gobo 6
				196-200	Shake of Gobo 7
				201-205	Shake of Gobo 8
				206-210	Shake of Gobo 9
				211-215	Shake of Gobo 10
				216-220	Shake of Gobo 11
				221-225	Shake of Gobo 12
				226-230	Shake of Gobo 13
				231-240	Shake of Gobo 14
				241-245	Shake of Gobo 15
				246-250	Shake of Gobo 16
				251-255	Shake of Gobo 17
11	12	16	Rotating Gobo Wheel	000-012	White
				013-025	Gobo 1
				026-037	Gobo 2
				038-050	Gobo 3
				051-062	Gobo 4
				063-075	Gobo 5
				076-088	Gobo 6
				089-101	Gobo 7
				102-114	Gobo 8
				115-127	Gobo 9
				128-155	Rotation (Clockwise from slow to fast)
				156-183	Reverse rotation(Anti-clockwise from slow to fast)
				184-191	Shake of Gobo 1
				192-199	Shake of Gobo 2
				200-207	Shake of Gobo 3
				208-215	Shake of Gobo 4
				216-223	Shake of Gobo 5
				224-231	Shake of Gobo 6

				232-239	Shake of Gobo 7
				240-247	Shake of Gobo 8
				248-255	Shake of Gobo 9
12	13	17	Gobo Rotation	000-128	Gobo Indexing (0°-540°)
				129-188	Rotation (Clockwise from slow to fast)
				189-195	Stop
				196-255	Reverse rotation (Anti-Clockwise from slow to fast)
	14	18	Gobo Rotation Fine	0-255	Gobo Rotation in 16 Bit
13	15	19	Prism	000-016	White
				017-255	Three-Facet Prism
14	16	20	Prism Rotation	000-128	Prism indexing (0°-540°)
				129-191	Rotation(Clockwise from slow to fast)
				192	Stop
				193-255	Reverse rotation(Anti- Clockwise from slow to fast)
15	17	21	Frost Filter	000-255	Linear Frost
16	18	22	Focus	000-255	Linear Focusing
		23	Focus Fine	000-255	Focusing in 16 bit precision
17	19	24	Zoom	006-255	Linear Zooming
		25	Zoom Fine	000-255	Linear Zooming in 16 bit precision
18	20	26	Pan	000-255	Pan(0°~540°)
	21	27	Pan Fine	000-255	Pan in 16 bit precision
19	22	28	Tilt	000-255	Tilt(0°~270°)
	23	29	Tilt Fine	000-255	Tilt in 16 bit precision
	24	30	Pan & Tilt Speeds	000-255	Pan & Tilt Speed from fast to slow
20	25	31	Control	000-047	Reserved
				048-080	Reset
				081-112	Reserved
				113-144	Lamp off( delay for 3 s)
				145-168	Reserved
				169-200	Lamp half power
				201-223	Reserved
				224-255	Lamp full power

Prism is prior to Frost Filter.

## MAINTENANCE

If the projector's lens becomes damaged or broken it should be replaced. If the lamp becomes damaged or deformed in any way it must be replaced. If the light from the lamp appears dim this would normally indicate that it is reaching the end of its life and it should be changed at once, aged lamps run to the extremity of their life might explode. If the projector does not function, check the fuses on the power socket of the projector, they should only be replaced by fuses of the same specification. The projector has overheat protection device that will switch off the projector in case of overheating. Should it happen, check if the fans are blocked or not, or if they are dirty, clean them before switching on the projector again.

**Any maintenance work should only be carried out by qualified technicians.**

## LUBRICATION

To ensure the smooth rotation of the rotating gobos and movement of the lens for focusing, it is recommended that the bearings for the rotating gobos and the 2 sliding tracks for the focusing lens holder be lubricated every two months. Use only high quality, high-temperature grease .

## KEEPING THE PROJECTOR CLEAN

To ensure the reliability of the projector it should be kept clean. It is recommended that the fans should be cleaned every 15 days. The lens and dichroic colour filters should also be regularly cleaned to maintain an optimum light output. **Do NOT use any type of solvent containing chemical elements on dichroic colour filters.**

Cleaning frequency depends on the environment in which the fixture operates. A soft cloth and typical glass cleaning products should be used in cleaning. It is recommended to clean the external optics at least once every 20 days and clean the internal optics at least once every 30 / 60 days.

**Do not use any organic solvent, e.g. alcohol, to clean the reflector mirror, dichroic colour filters or housing of the apparatus.**

## TROUBLESHOOTING

PROBLEM	ACTION
The projector doesn't switch on	<ul style="list-style-type: none"><li>➤ Check the fuse on the power socket.</li><li>➤ Check the lamp.</li></ul>
The lamp is on but the projector doesn't respond to the controller	<ul style="list-style-type: none"><li>➤ Make sure that the fixture's start address is right</li><li>➤ Replace or repair the XLR signal cable.</li></ul>
The projector functions intermittently	<ul style="list-style-type: none"><li>➤ Make sure the fan is working well or fans and their shields are not blocked</li></ul>
Beam appears dim, Low in brightness	<ul style="list-style-type: none"><li>➤ Make sure the lamp is within its lifespan</li><li>➤ Remove dust or grease from the lenses.</li></ul>
The project image appears to have a halo	<ul style="list-style-type: none"><li>➤ Carefully clean the lamp, optical lenses and other components.</li></ul>
Heavily Defective Beam	<ul style="list-style-type: none"><li>➤ Check if lens are in good condition(not cracked)</li><li>➤ Clean dust or grease on the lens.</li></ul>

## TECHNICAL DATA

### **VOLTAGES:**

100V~240V AC, 50/60Hz

### **POWER CONSUMPTION:**

350W@ 220V

### **LAMP:**

OSRAM	SIRIUS HRI 230W
Colour Temperature	8000K
Manufacturers Rated Lamp Life	3000hours

### **COLOURS:**

CMY linear color mixing system with Marco  
1 Color Wheel with 14colors plus white  
With variable speed bi-directional rainbow effect  
Stepping/linear color changing

### **FIXED GOBO WHEEL:**

1 Fixed gobo wheel : 17gobos+ White  
Shake and Bi-directional wheel scroll at variable speeds

### **ROTATING GOBO WHEEL:**

1 Rotating Gobo Wheel: 9gobos +White  
Shake and Bi-directional wheel scroll at variable speeds  
Rotating Gobo Replaceable

### **IRIS:**

Macro Function

### **PRISM:**

1pc,3-facet rotating Prism(bi-directional with variable speeds)

### **FROST:**

1pc frost filter

### **FOCUS:**

DMX linear Focusing

### **ZOOM:**

DMX linear Zooming

### **DIMMER:**

0-100% linearly adjustable

**SHUTTER:**

Double shutter blades, 0.3~25 F.P.S

**HEAD MOVEMENT:**

Pan 540°, Tilt 270° with auto position correction

**BEAM ANGLE:**

Zoom: 3.8°-42°, linearly adjustable

**CONTROL:**

DMX512, 3 pin and 5 pin interfaces

20 channels in short mode, 25channels in standard mode and 31 channels in extended mode

Self-test mode

**OTHER FUNCTIONS:**

Adjustable Pan & Tilt speed

Use time display for the projector and the lamp respectively

Modular Structure for easy maintenance

Optional DMX512 Wireless Transmitter

**HOUSING:**

High temperature Engineering plastic, IP20

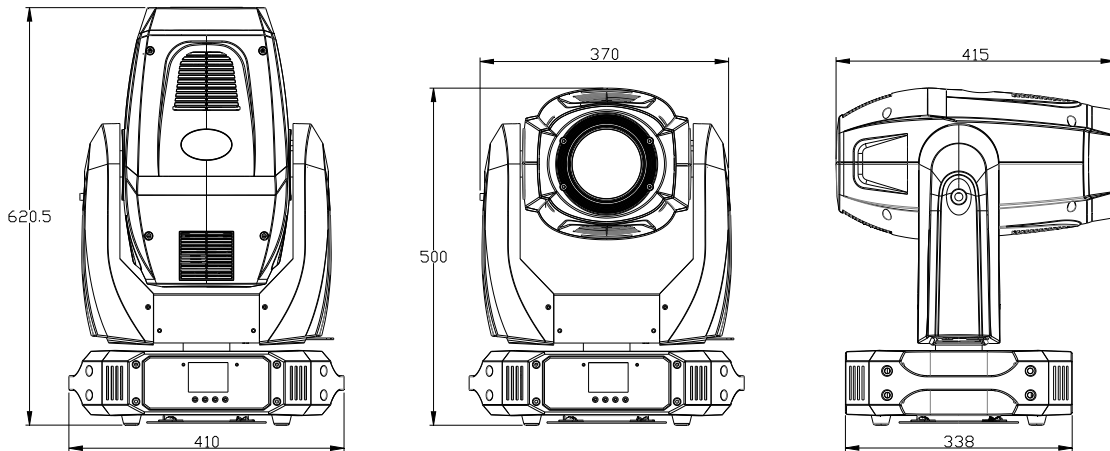
**NET WEIGHT:**

22Kg

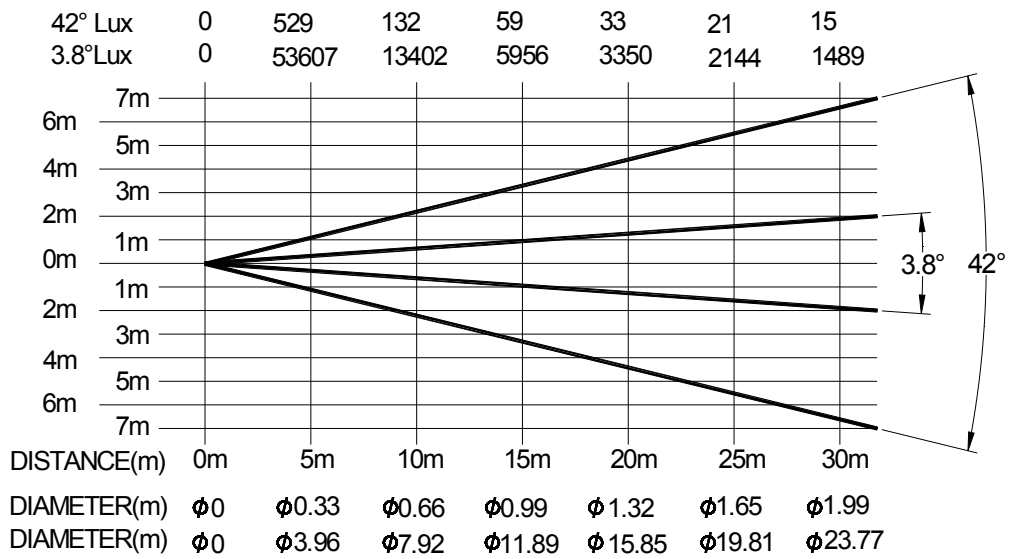
**GROSS WEIGHT(in Flight Case):**

54Kg

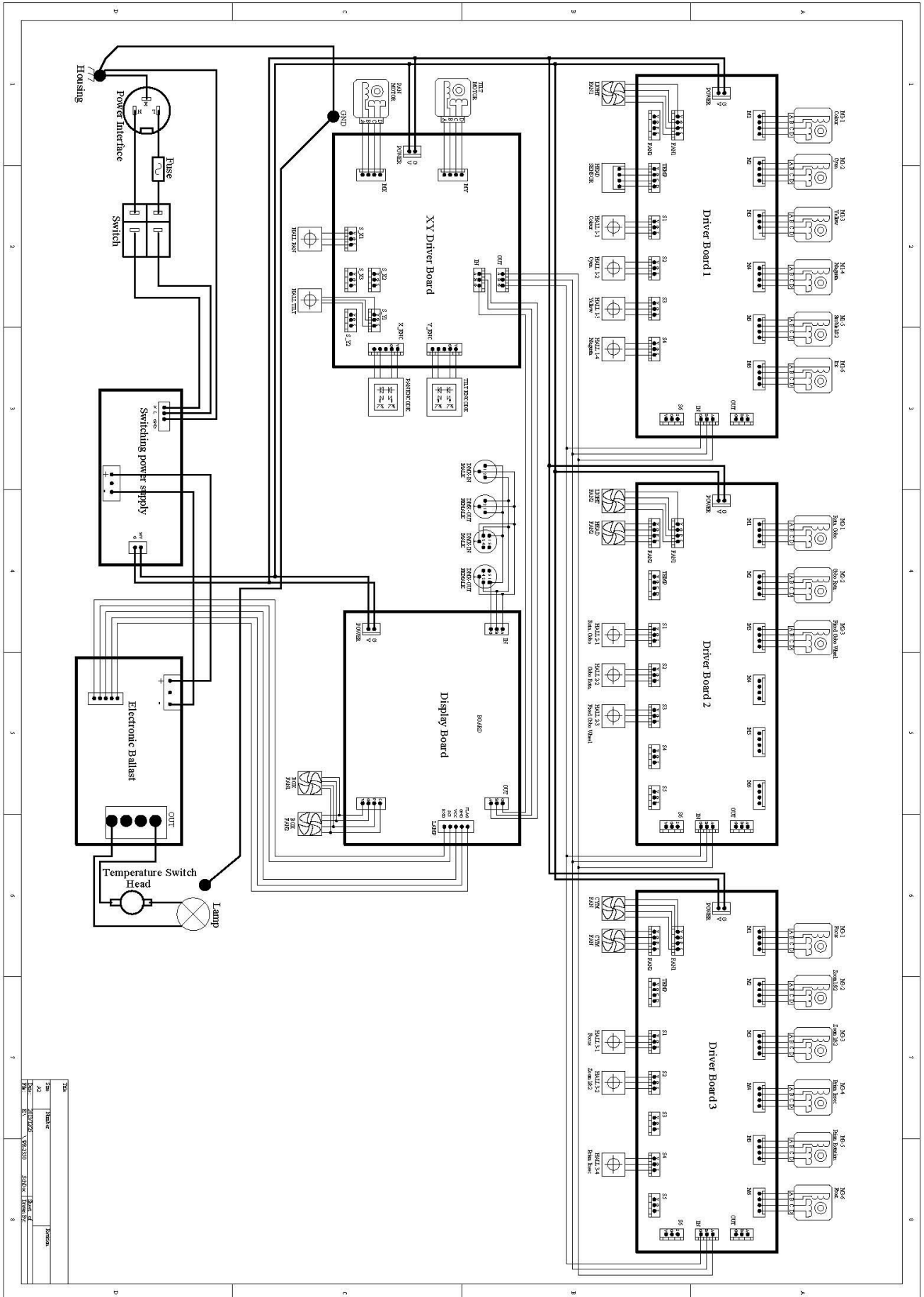
**SIZES:**



**LIGHT OUTPUT:**



# ELETRICAL DIAGRAM:



NO.	REV.	DATE	BY	CHK.
1	1	2023-03-20	SAUNDRA	ARMSTRONG

## Component Order Codes

NAME	PART NO.	QUANTITY	REMARK
Pan Motor	030040233	1	
Tilt Motor	030040233	1	
Dimmer/Strobe Motor	030040213	2	
CYM Motor	030040228	3	
Rotating Gobo Wheel Motor	030040231	1	
Fixed Gobo Wheel Motor	030040221	1	
Color Wheel Motor	030040221	1	
Iris Motor	030040230	1	
Rotator Motor	030040221	1	
Focus Motor	030040232	1	
Frost Motor	030040221	1	
Zoom Motor	030040215	2	
Prism Rotation Motor	030040224	1	
Prism Move-in Motor	030040221	1	
Fan	030060086	2	At Rear side of the lamp
Turbo- Fan	030060064	1	Lamp Cooling
Fan	030060088	2	In the middle of Head
Fan	030060089	2	Base
Ballast	040070112	1	
Lamp	100070029	1	
Rotating Gobo Wheel Accessory	120110615	1	
Color Wheel Accessory	120110609	1	
Fixed Gobo Wheel Accessory	120110616	1	
Power Switch	192010171	1	
LCD Master Board	230020678	1	
6 channel driver board1	230020680	1	
6 channel driver board2	230020681	1	
6 channel driver board3	230020682	1	
XY Driver Board	230060274	1	
Fuse	270041079	1	
Tilt Belt	290151244	1	
Zooming Belt	290151383	2	
CYM Belt	290151382	3	
Prism Wheel Move-in Belt	290151384	1	
Gobo Rotation belt	290151260	1	
Pan Belt	290151223	1	
Prism Wheel Rotation Belt	290151385	1	
Focusing Belt	290151383	2	

PR LIGHTING LTD.

---

1582 Xingye Avenue, Nancun Panyu  
Guangzhou, 511442 China  
TEL: +86-20-3995 2888  
FAX: +86-20-3995 2330

---

P/N: 320020212  
Version: 20140108 (Preliminary)