

# UniMIX™



## Multi Channel Transformer isolated AV/Podcast Mixer



These days, more and more educational institutions such as colleges, universities and high schools are expected to provide downloadable recordings - podcasts - of lectures and classes, for students to access at all times on the local area network. These recordings are typically taken from the classroom/lecture theatre sound system and saved to a computer in real time.

**Problem 1:** Getting the correct level is hard, given that the level requirements are different to those of speakers.

**Problem 2:** Maintaining a steady input level to the computer requires continual monitoring to prevent digital overload.

### The Solution

Introducing the new **UniMIX** from ARX: Six Balanced XLR Mic / Line input channels with individual level controls, plus a dedicated stereo RCA jack Line In channel.

Each Mic/Line input has infinity to +6dB of Level available on the front panel, as well as a 10 to 50dB Input Gain control. The stereo Line Input channel has a -10 to +10dB Level Trim control, to allow accurate matching of any line level signals.

On the rear panel, each of the 6 electronically balanced Mic inputs can be switched to Line via individual switches.

### Multiple Masters

For the room system, the **UniMIX** has 2 Balanced XLR outputs, with 3 way EQ and its own Master Level control.

The Recording Outputs are stereo

balanced jacks, transformer isolated to prevent ground loops and associated noise.

### Automatic Gain Control

The Recording Master also has its own Automatic Gain Control circuitry. Specially tailored parameters ensure that levels remain constant, irrespective of Mic placement and user technique.

The result is a consistent level for the recording, removing the need for fulltime monitoring and the risk of overloading and distortion.

The final Master control feeds the main signal to a transformer isolated Balanced XLR Auxiliary Output. This can be used for future expansion, remote monitoring or for feeding a wireless transmitter or other device.

Global Phantom Power is available on all Microphone inputs via a rear panel switch with associated front panel status LED.

### Wide Dynamic Range

Internally, careful attention to the signal path design, using precision components found in high-end mixing consoles, has resulted in a unit with very wide dynamic range. The **UniMIX** has enough headroom to cope with the hottest line signal, and better than digital noise specifications

### Universal AC Power

AC power range is a universal 100 to 120V or 220 to 240V AC, and is connected to the unit via a standard three pin IEC connector, with built-in fuse and voltage change switch.

## Features

- ✓ Automatic Gain Control for consistent audio recording levels
- ✓ 6 Mic/Line Input channels with Balanced XLR Inputs
- ✓ Dedicated stereo Line In channel
- ✓ Individual Level controls from 00 through to +6dB
- ✓ Master Level controls
- ✓ Dedicated Transformer Isolated Recording Level control with Balanced Jack Outputs
- ✓ Transformer Isolated Balanced XLR Auxiliary Output
- ✓ Numbered Marker panels for channel assigns
- ✓ Headroom to handle the hottest signals
- ✓ Flawless performance in any audio environment

# Specifications



## Input Impedance

- Mic 4K Ohms Balanced
- Line 22K Ohms Unbalanced

## Input Gain

- Microphone Variable 10 dB to 50 dB with rear trim control
- Mic / Line switch -20dB

## Output Level (Max) +21dB

## AGC Threshold

- 30 to 0 dB

## AGC Output Gain

- 20 to +20 dB

## Phantom Power

- +48VDC switchable on all Microphone Inputs

## Output Signal/Noise

- (@ unity gain)
- 90dB A weighted, all inputs @ Unity, Master @ Unity

## Dynamic Range 115dB

## Master Output EQ

- Low 100Hz 15dB Cut/Boost
- Mid 800Hz 15dB Cut/Boost
- Bell curve, Broad Q
- High 10KHz 15dB Cut/Boost

## System Master Outputs

- Electronically Balanced XLR
- 300 ohms, Amphenol Male XLR:
- Pin 1 Ground, Pin 2 +, Pin 3 -

## Auxiliary Output

- Transformer Balanced XLR
- 300 ohms, Amphenol Male XLR:
- Pin 1 Ground, Pin 2 +, Pin 3 -

## Recording Outputs

- Transformer Balanced TRS
- Balanced Jacks, 300 ohms

## Frequency Response

- 20Hz-20 KHz ± 1dB

## Distortion (@ unity gain)

- Below 0.0035%,
- 100 Hz to 10KHz

## Input Connector Type

- Mic/Line - Amphenol Female XLR
- Pin 1 Ground, Pin 2 +, Pin 3 -
- Hi Z Input - Phono (RCA type)

Our policy is one of continuous improvement, and therefore designs may change without notice. However, unless otherwise stated, specifications will always equal or exceed those previously given.



©2007 ARX Systems Pty.Ltd. ACN 006 471 825. All rights reserved. ARX Systems® is a Registered Trade Mark.



- Individual Level controls for each input channel - infinity through 0db to +6dB
- Individual Gain Controls for each Input channel, 10 to 50 dB
- Stereo Line In Level and Trim control
- Master Output 3 way EQ and Level control
- System Status LEDs
- Recording Master Level control and Automatic Gain Control Threshold trim
- Auxiliary Master Output control
- Marker panel for labelling input channels



- 6x Female XLR Balanced Inputs wired Pin 1 Audio Ground, Pin 2 +, Pin 3 -
- RCA type Stereo Line Inputs
- Left and Right Transformer isolated TRS Balanced Recording Output jacks
- Left and Right Male XLR Balanced Outputs, wired Pin 1 Audio Ground, Pin 2 +, Pin 3 -
- Transformer isolated Auxiliary Master XLR Output
- Global Mic input Phantom Power switch
- Removable IEC type AC input connector, with inbuilt fuse

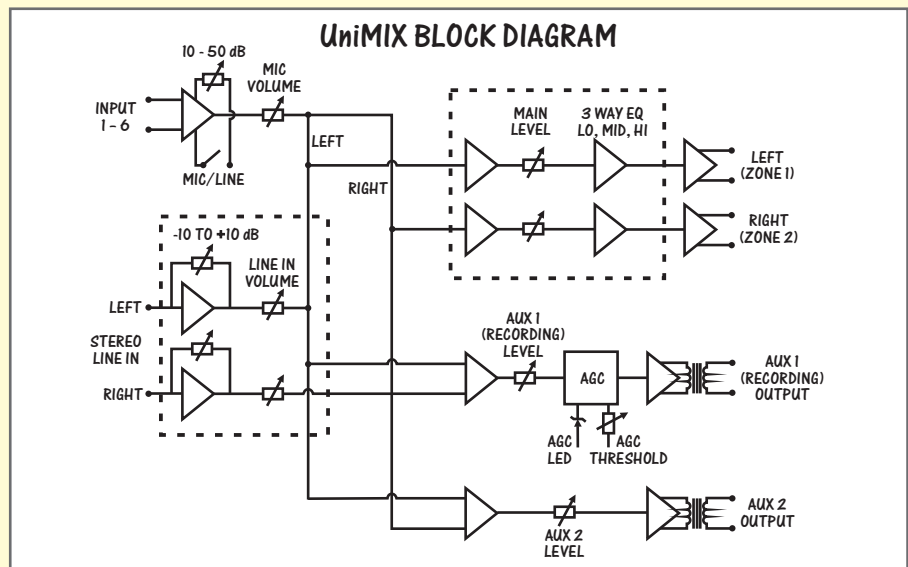

## ARCHITECTURAL SPECIFICATIONS

The mixer shall be mounted into a standard 1 RU steel chassis with extruded anodised aluminium front panel. It shall have six input channels switchable to Mic or Line, with one Level control per input. Each level control shall provide full attenuation through to +6dB of gain. An associated Gain control shall have 10dB to 50 dB Gain. There shall also be a stereo Line input channel, with RCA type phone connectors. It shall have its own Level control, and an associated -10 to +10 dB Input Trim control. On the rear panel, all Mic/Line Inputs shall be electronically balanced 3 pin female XLR connectors. There shall be a Master Level control with three way EQ on the front panel, and the Master outputs shall be electronically balanced 3 pin male XLR output connectors. There shall also be a single transformer balanced XLR Auxiliary Master output with associated front panel Level control.

There shall also be a Recording Output Master control on the front panel, with associated Automatic Gain Control. The outputs shall be transformer balanced Tip Ring Sleeve balanced jacks. 48V DC Phantom Power shall be available on all Mic Inputs via a rear panel switch. Input Headroom shall be +24dB, and Maximum Output Level shall be +24dB. Output Signal/Noise @ unity gain shall be -90dB A weighted, Master @ unity, Frequency Response shall be 20Hz-20KHz ±1dB. Distortion @ unity gain, shall be below .0035% 100Hz to 10KHz. AC power shall be switchable 100 to 120V or 220 to 240V AC, connected to the unit via a standard three pin IEC connector, with built-in fuse and voltage change switch. The unit shall be the ARX UniMIX

ARX Systems Pty Ltd, PO Box 15, Cheltenham, Victoria 3192, Australia  
 Phone +61 (0)3 9555 7859 Fax 03 9555 6747 International Fax +61 (0)3 9555 6747  
 Email: info@arx.com.au Internet: www.arx.com.au