



ORIGIN®
ACOUSTICS

Installation Manual

Director 8 Collection

Models:

D80

D82

D82 DT/SUR

D84

D86

D88



Introduction

Thank you for purchasing the Director 8 In-Ceiling Speaker. At Origin Acoustics, we take pride in providing you with a high quality product. All of Origin Acoustics' speakers are designed to have excellent sound quality, longevity, and a simple installation process.

This instruction booklet covers the necessary information for a smooth installation of your Director, including: the tools you will need, step-by-step instructions for installation, troubleshooting tips for any errors that may occur, and all warranty information. If for any reason you experience problems or if you have installation questions please call us at (844) 674-4461. Hours of operation are 8:00am to 5:00pm (Pacific Time), Monday through Friday.

Table of Contents

Introduction	1
Installation Requirements and Recommendations	1
What's included.....	1
Required Tools/Items.....	2
Optional Tools/Items.....	2
Model D82 DT/SUR	3
Dual Tweeters.....	3
Surround (Dipole).....	3
Stereo (Bipole).....	3
Speaker Placement	4
Home Theater (5 Speakers).....	4
Installation	5
1) Installing the Wire.....	5
2) Painting the Grille.....	7
3) Cutting the Hole.....	7
4) Installing the InstaMount.....	8
5) Connecting the Wires.....	9
6) Installing the Speaker.....	9
7) Listening Test and Adjustments.....	10
8) Installing the Grille.....	11
Troubleshooting	12
Technical Assistance	13
Specifications	15
Warranty	16
Limited Lifetime Warranty.....	16
Requirements and Warranty Coverage.....	17
Return Process.....	17

Installation Requirements and Recommendations

What's included

- Template
- Speaker
- InstaMount (with 4 detachable ZipClips)
- Grille

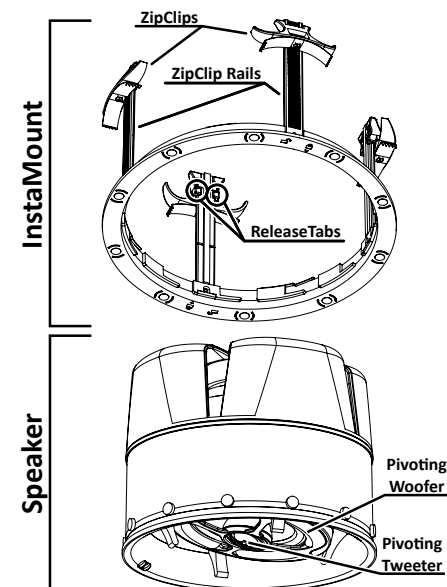



Model D82 DT/SUR

Required Tools/Items

1. Keyhole or drywall saw
2. Speaker wire
3. Pencil
4. Wire stripper
5. Measuring tape

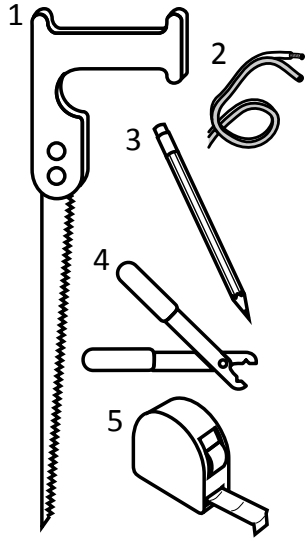

Speaker Wire Recommendations

For this setup, use a multi-stranded wiring designed for amplifier to speaker connections. The gauge of wire used can have an impact on the performance of your speakers and we would recommend that you choose the largest wire size that is practical for your installation. Which gauge to select depends on the length of wire to be used on any particular speaker. In general the shorter the run the smaller the wire size you can use, however you can never go wrong by using a thicker gauge.

Wire Length		Recommended Gauge
Feet	Meter	
0-100	0-30	16
50-150	15-45	14
100+	30+	12

Optional Tools/Items

- Drill with 1/8" (3mm) drill bit To check for obstacles in ceiling
- Stiff wire (like from a coat hanger) To check for obstacles in ceiling
- Stud finder To check for obstacles in ceiling
- Fish tape To route wire through walls
- Can of spray paint For painting the grille
- Can of compressed air For painting the grille

Dual Tweeters

The Dual Tweeter models can be used for either one channel (surround) or two channels (stereo). A switch is located on the back of the speaker to select which mode to use. One of the inputs is labeled for surround. This is the input that should be used if you're only using one channel.

Surround (Dipole)

In this mode, one channel is fed into both tweeters to be distributed throughout the area. This way in a multiple-speaker setup, one speaker can be a dedicated left speaker and another a dedicated right.

Stereo (Bipole)

In this mode, two channels are fed into the speaker: one channel for each tweeter. This setup is ideal for small rooms such as walk-in closets and bathrooms, as well as oddly-shaped areas such as hallways. With both left and right channels in one speaker, only one speaker is needed in smaller rooms. Or in areas like hallways, both channels can be evenly distributed throughout the area with multiple speakers.

WARNING

If you are using a dual tweeter speaker in stereo mode (i.e. there are two wires connected to the speaker: one for the left channel and one for the right), **do not** set the switch to surround mode. This could damage the amplifier.



Speaker Placement

Auxiliary Room (2 Speakers)

Position the two speakers in the middle of the room, no less than 6' (2m) apart. Ideally, the two speakers would be placed an equal distance from the listener. If the room has a lower ceiling, the speakers can be closer together. Also, if the speaker placement is intended for standing (as opposed to sitting) listeners, the speakers can be closer together. Figure 4.1 shows the sound coverage of the room.

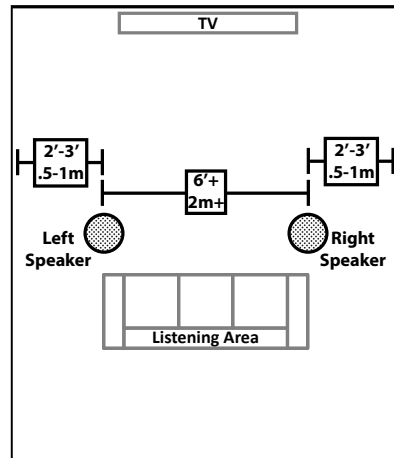
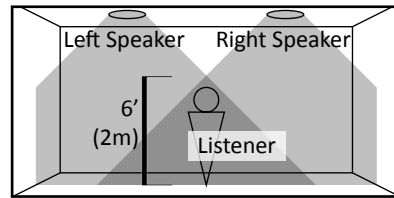

(The D82 DT/SUR speakers should be located directly to the side of the listener, unlike the other models.)

Home Theater (5 Speakers)

The Left Rear (LR) and Right Rear (RR) speakers should be installed just behind the listener, one on either side. The Center Channel (CC) speaker should be placed above and slightly in front of the television, with the Left Front (LF) and Right Front (RF) speakers placed equidistant to either side.

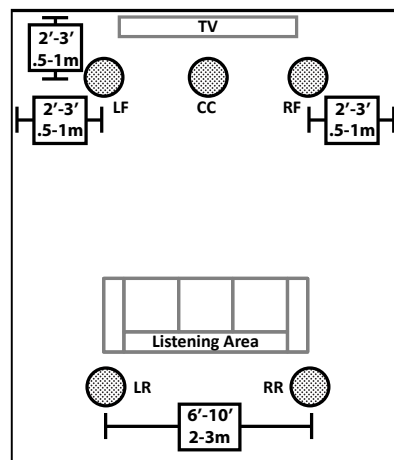

Installation

1) Installing the Wire

Strip $\frac{1}{4}$ to $\frac{1}{2}$ inches (6 to 12 mm) of the insulation off both ends of the wire. To avoid stray strands, twist them at the end.

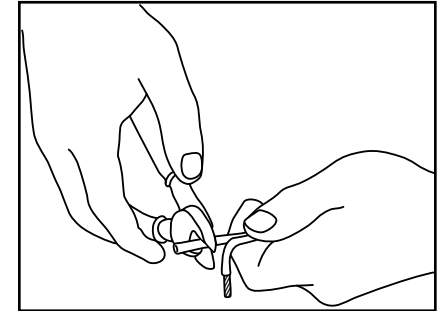

Connect the wire to the amplifier, and make sure the wire connected to the left speaker output will be routed to the left speaker, right output to right speaker, etc.

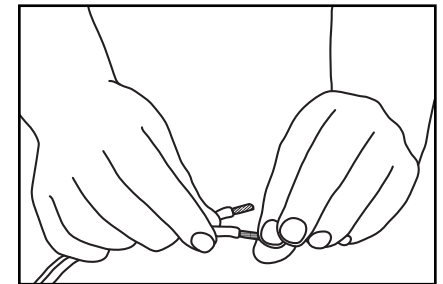

About Speaker Wire

You will need a wire that has at least two conductors; one that can be identified as the positive and the other as the negative. All two conductor wires have some means of identifying which conductor is which, but at times this identification may be subtle. It's crucial that you keep track of which wire you use for positive (+) and negative (-). Typically if the wires are colored red and black, the red wire is used for positive and the black wire is used for negative, but sometimes other colors or patterns are used. You can choose whichever color of wire you want to be positive and negative as long as you remain consistent throughout the install.

On both your amplifier and your speaker the connectors will be identified as red for positive and black for negative. It is very important to look carefully at the speaker wires and be certain that the same wire that is attached to the positive connector in the amplifier is attached to the positive connector in the speaker.



Plan how you'll route the wire to the desired speaker location. There are several methods for routing the wire, and you may need to combine several of them.

Under the Carpet:

One option is to lift up the carpet and rout "tape wire" under the carpet.

Behind the Baseboard:

The wire can be routed behind the baseboard by cutting a groove out of the back of the baseboard, or by buying special baseboard designed for concealing wires.

Through an Attic, Crawlspace or Basement:

When available, you can route the wire through an attic or crawlspace.

Through walls:

When running wires through a wall, be sure to avoid all obstacles such as AC wiring, pipes, and ducts.

For New Construction

If these speakers are being installed in a new home during construction, the installation process will be a bit different (although much simpler). For these situations, it's recommended you purchase a bracket. Instructions on how to install the speakers are provided with the bracket, or can be found on our website. Visit www.originacoustics.com for more information.

2) Painting the Grille

In some situations the speakers may look better if the color matched the walls, ceiling, or trim in the room. This can be accomplished by painting the grille. The grille must be painted with spray paint, and most hardware stores will mix a can of paint to match whatever color you need.

Before painting, carefully remove the thin cloth on the underside of the grille. Lightly spray the front of the grille with the paint from a distance, being careful not to plug any of the holes. Diluting the paint with paint thinner will lessen the risk of filling any holes. If a hole gets plugged use a can of compressed air to open it. Once the paint is dry, put the cloth back on the grille.

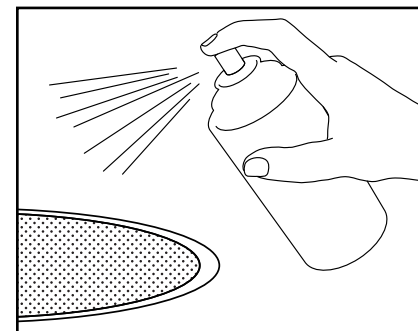
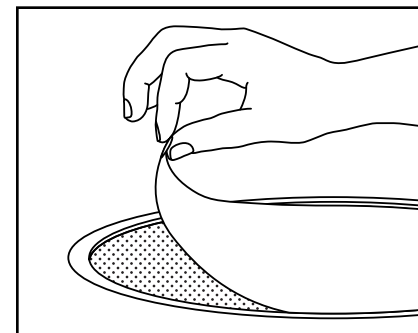

3) Cutting the Hole

When you've decided on the locations for all of the speakers, use the template to trace a circle lightly in pencil where the hole should be. (If you don't have a template, check the Specifications section for cutout sizes.) If you're unsure on whether there may be obstacles (such as pipes or wires) where you plan on installing the speaker, drill a 1/8 inch hole in the center of the circle, then put a bent coat hanger through the hole to feel around. Use a keyhole or drywall saw to cut the hole.



4) Installing the InstaMount

Adjust the ZipClips so that they're positioned at the top of the rail. If they're not already there you can do this by pushing the release tabs (or metal "buttons") on the inside of the rail and pulling the ZipClips to the top of the rails.

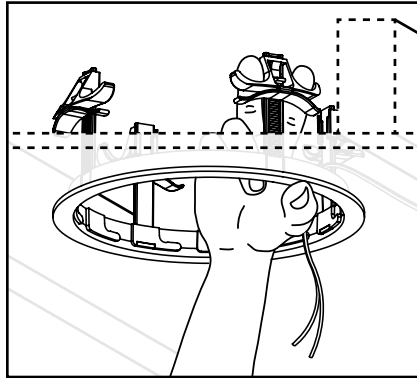

Insert the InstaMount into the hole in the ceiling by gently bending the ZipClips inward. Reach inside the InstaMount and push the ZipClips down so that the InstaMount is firmly in place, but not too tight.

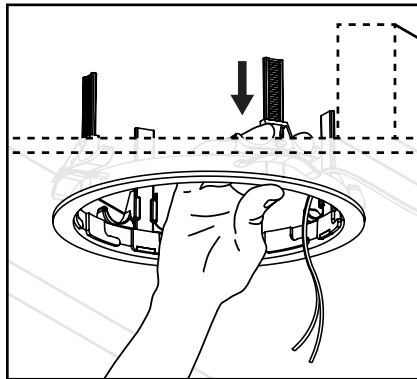

If for some reason the InstaMount needs to be removed, reach inside and push the release tabs to fully remove the ZipClips. After the ZipClips have been removed, the InstaMount can be taken out.

Installation Video

To watch a video on how to install the InstaMount and speaker, visit our website at: www.originacoustics.com

5) Connecting the Wires

Insert the wires into the connectors, making sure that the positive wire is being attached to the red connection and the negative wire is being attached to the black connection. If the negative and positive wires are switched, speaker performance will be drastically impacted.

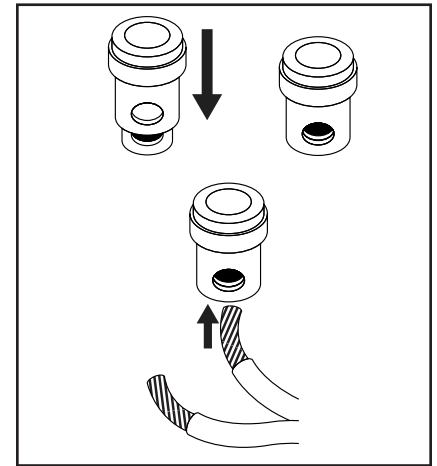

6) Installing the Speaker

Fit the speaker into the InstaMount, and twist it clockwise into place. When the arrow on the speaker lines up with one of the arrows on the InstaMount, that means the speaker is tightly in place. **Be sure that the arrows line up**, otherwise there's a risk that the speaker will fall out of the ceiling.

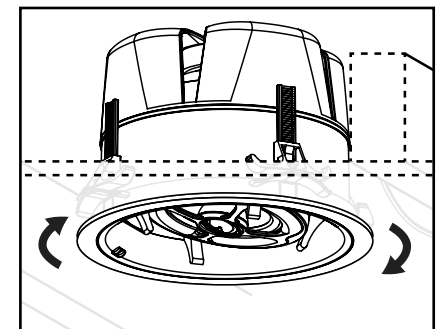
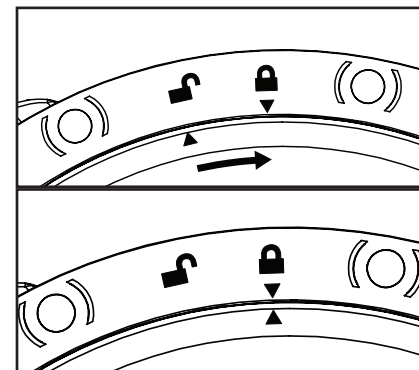
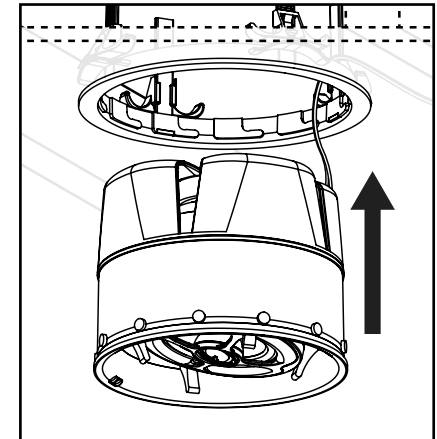



7) Listening Test and Adjustments

The midrange on the D84, D86, and D88 and tweeter on all but the D82 DT/SUR can be pivoted to direct the sound towards the listening area. Or for a more diffused surround sound experience, the rear speakers can be aimed towards the wall. To aim the tweeter, gently apply pressure to the rim with your thumbs to pivot the tweeter. To aim the midrange, gently apply pressure to the rim and pivot it in the desired direction.

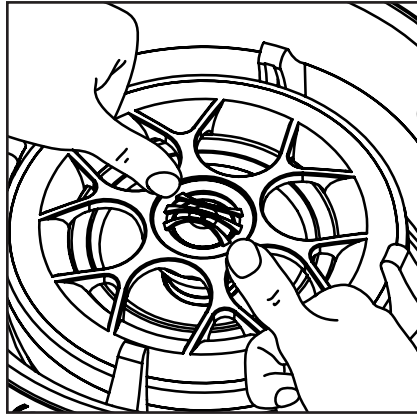

The D86 and D88 have two switches: one to adjust the treble, and one to adjust the bass. The D84 only has one switch for treble.

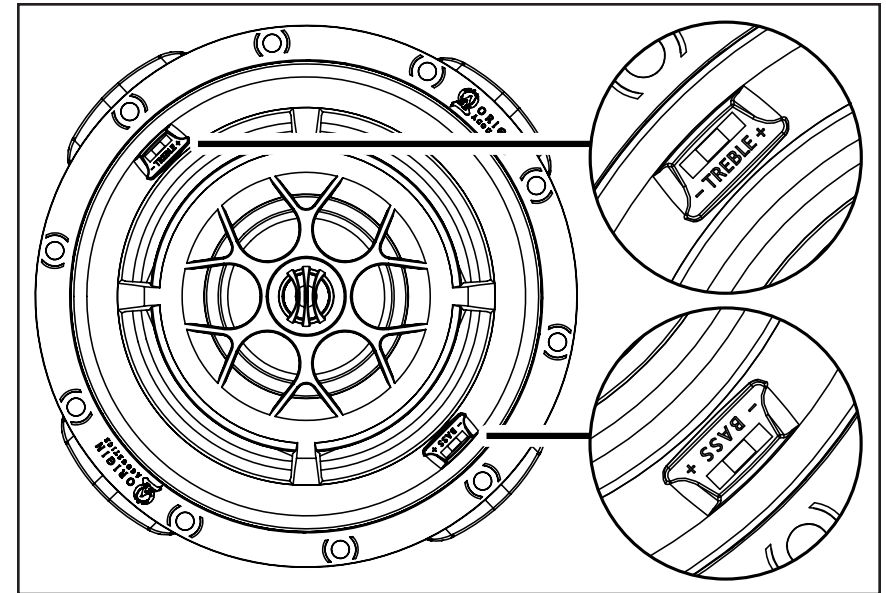
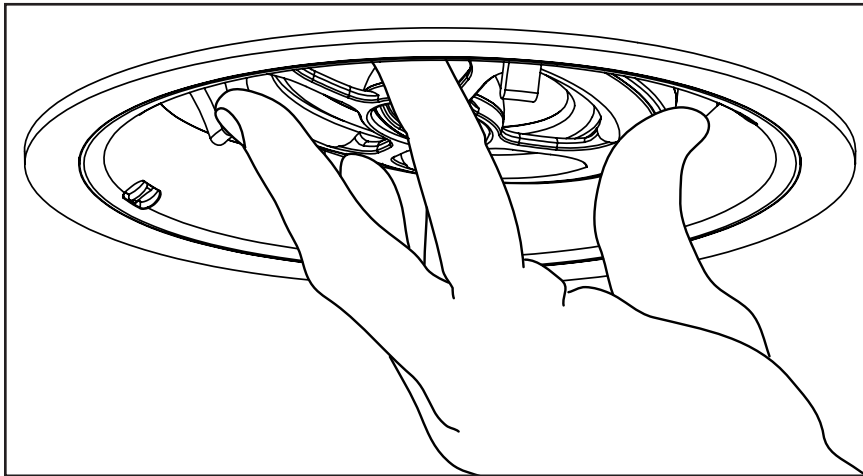

Reasons to Adjust Bass and Treble

Bass: When a speaker is installed in a corner, the bass is amplified. If this is the case, it may be best to turn the bass down.

Treble: When a room has a lot of hard surfaces like bare walls and hardwood floors, the treble will reflect off of these surfaces and increase. In these situations, it may be a good idea to turn the treble down. Alternately, in rooms with carpet and things like curtains, the treble is often absorbed. If this is the case, it would probably be best to turn up the treble.

8) Installing the Grille

Fit the grille over the speaker. The grille uses magnets to be held in place.



Troubleshooting

If possible, it's often good to try to isolate the problem first. For example, if you're playing a DVD on a television and there's no sound, try connecting an MP3 player to the system to see if that works. If it does work, then the problem is with the television, DVD player, or the cables connecting them. If it doesn't work, the problem will be with the amplifier, speakers, or those cables.

Problem	Possible Cause
No Sound	The volume may be turned down or muted. Check the volume settings on both the amplifier and the television/computer/CD player/etc.
	Make sure the proper source is selected on the amplifier or receiver.
	Check the cord connecting the amplifier with the source. The cord may be damaged or plugged into the wrong input or output.
	Check the wires connecting the amplifier with the speakers. Make sure they're connected properly and not damaged in any way.
Poor Sound Quality	If you hear something like static, or the sound is cutting in and out, check the audio cables. If the problem increases when a cable is being moved, then the cable is most likely faulty or not connected properly.
	Today's audio systems may have several places to adjust the volume, for example your MP3 player may have a volume control, and your amplifier may also have one. Check to be certain that the volume isn't turned up past 80% on any device.
	Try changing sources to be certain that the selection you've chosen is a good quality recording.

Technical Assistance

If you have any questions or concerns about installing or using this product, you can reach us through one of the following methods:

Phone: (844) 674-4461

Hours of operation: 8:00am - 5:00pm (Pacific Time), Mon - Fri

Email: techsupport@originacoustics.com

If you are having technical trouble, please include the model number and briefly explain what steps you took to resolve the problem in your email, or be prepared to answer these questions over the phone. If you are considering returning the product, it's required that you contact Origin Acoustics prior to any return attempts. This way we can determine if the issue can be resolved without returning the product, or if needed we can provide instructions and support for the return process.



Specifications

Model Number	D80	D82	D82 DT/SUR	D84	D86	D88
Part Number	SCD80000	SCD80200	SCD2T80200	SCD80400	SCD80600	SCD80800
Tweeter Dome	Silk	Aluminum	Aluminum	Aluminum	Silk DPSD*	Silk DPSD*
Tweeter Diameter	1" (25mm)	1" (25mm)	1" (25mm)	0.75" (20mm)	0.75" (20mm)	0.75" (20mm)
Midrange Cone	N/A	N/A	N/A	IMG	Glass	Kevlar
Midrange Diameter	N/A	N/A	N/A	4" (102mm)	4" (102mm)	4" (102mm)
Woofers Cone	Polypropylene	IMG	IMG	IMG	Glass	Kevlar
Woofers Diameter	8" (203mm)	8" (203mm)	8" (203mm)	8" (203mm)	8" (203mm)	8" (203mm)
Adjustments	N/A	N/A	N/A	Treble	Treble & Bass	Treble & Bass
Frequency Response	38Hz-20kHz	38Hz-20kHz	38Hz-20kHz	36Hz-20kHz	34Hz-20kHz	30Hz-20kHz
Impedance	8 ohm	8 ohm	8 ohm	8 ohm	8 ohm	8 ohm
Power Handling	20-100 watts	50-125 watts	50-125 watts	50-150 watts	50-175 watts	50-200 watts
Sensitivity	87dB ± 3dB	89dB ± 3dB	89dB ± 3dB	89dB ± 3dB	90dB ± 3dB	90dB ± 3dB
Diameter	9.625" (244mm)	9.625" (244mm)	9.625" (244mm)	9.625" (244mm)	9.625" (244mm)	9.625" (244mm)
Cutout Diameter	8.75" (222mm)	8.75" (222mm)	8.75" (222mm)	8.75" (222mm)	8.75" (222mm)	8.75" (222mm)
Mounting Depth	3.875" (98mm)**	4.625" (116mm)**	4.625" (116mm)**	7.375" (187mm)	7.375" (187mm)	7.375" (187mm)

*DPSD = Dual Plane Stabilized Diaphragm

**The ZipClip Rails have a mounting depth of 5.3125" (135mm), but they can be trimmed to be the depth listed above.



Warranty

Limited Lifetime Warranty

Origin Acoustics warrants to the original retail purchaser only that this Origin Acoustics product will be free from defects in materials and workmanship, provided the speaker was purchased from an Origin Acoustics authorized dealer.

If the product is determined to be defective, it will be repaired or replaced at Origin Acoustics' discretion. If the product must be replaced yet it is no longer manufactured, it will be replaced with a model of equal to or greater value that is the most similar to the original. If this is the case, installing the replacement model may require mounting modifications; Origin Acoustics will not be responsible for any such related costs.

Requirements and Warranty Coverage

This warranty may not be valid if the product was purchased through an unauthorized dealer. This warranty only applies to the individual that made the original purchase, and it cannot be applied to other purchases. The purchaser must be prepared to provide proof of purchase (receipt). This warranty will not be valid if the identifying number or serial number has been removed, defaced, or altered.

This warranty does not cover the following:

- Accidental damage
- Damage caused by abuse or misuse
- Damage caused by attempted repairs/modifications by anyone other than Origin Acoustics or an authorized dealer
- Damage caused by improper installation
- Normal wear, maintenance, and environmental issues
- Damage caused by voltage inputs in excess of the rated maximum of the unit
- Damage inflicted during the return shipment

Return Process

Before making any return attempts, it is required that you first contact Origin Acoustics. Return product to Origin Acoustics or your dealer, either in person or by mail. It's preferable if the product is returned in the original packaging. If this isn't possible, the customer is responsible for insuring the shipment for the full value of the product.

This warranty is in lieu of all other expressed or implied warranties. Some states do not allow limitations on implied warranties, so this may not apply depending on the customer's location. (For more information, see Magnuson-Moss Warranty Act.)

©2014 Origin Acoustics. All copyrighted, trademarked and patented elements mentioned herein are the sole property of Origin Acoustics.

