

eMOTUS5P

SURFACE MOUNT CABINETS

Powered Loudspeakers - Stereo kit



PRODUCT OVERVIEW

eMOTUS5P is a stereo loudspeaker kit including an active and a passive cabinet and performing 2 audio inputs: balanced and unbalanced. A professional and compact loudspeaker stereo kit, a user-friendly and cost-effective formula with a fantastic performance and a unique design that will easily fit in a massive number of multimedia applications: education classrooms, corporate meeting rooms, retail stores, etc. Available in black and white colour.

KEY FEATURES

- Stereo kit: 2x25W RMS
- 2-ways: 5" woofer + 1" tweeter
- 2 analogue audio inputs (balanced- Euroblock and unbalanced-RCA)
- Sound source selection
- 2-band tone control
- Stereo/mono switch
- Auto stand-by
- Available in black and white finish

APPLICATIONS

- Classrooms
- Meeting rooms
- Multimedia presentations (in combination with video projectors, screens, etc.)
- Retail shops
- Museums and exhibitions
- Hotel rooms

MECHANICAL DIAGRAMS

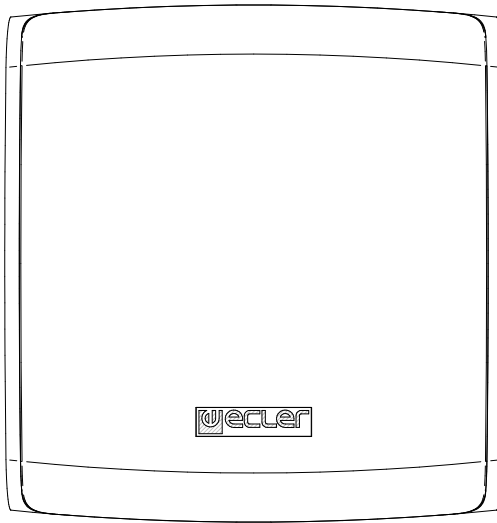

FRONT

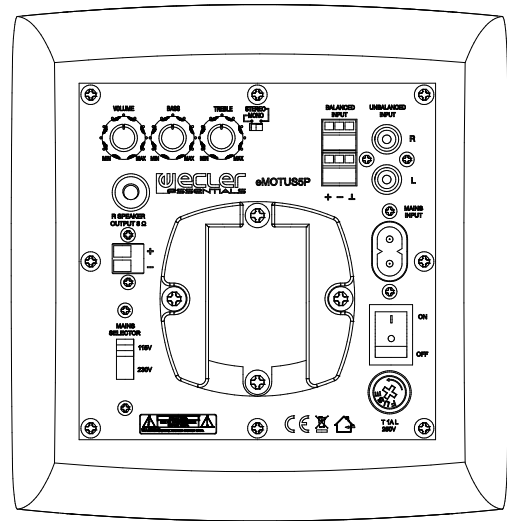

REAR

WALL SUPPORT MOUNTING DIAGRAM

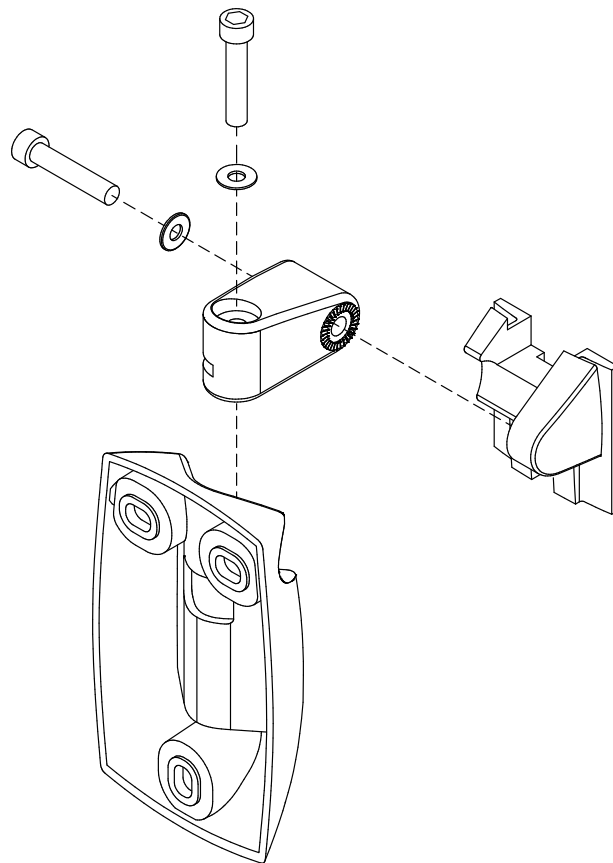

POLAR DIAGRAMS

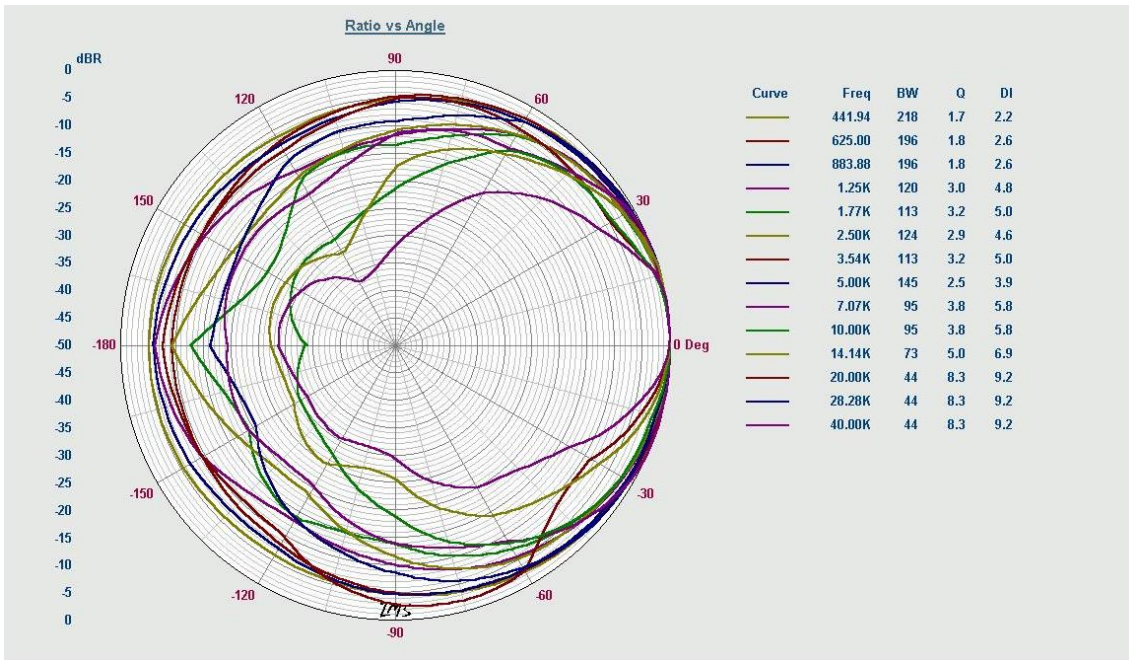

FREQUENCY RESPONSE

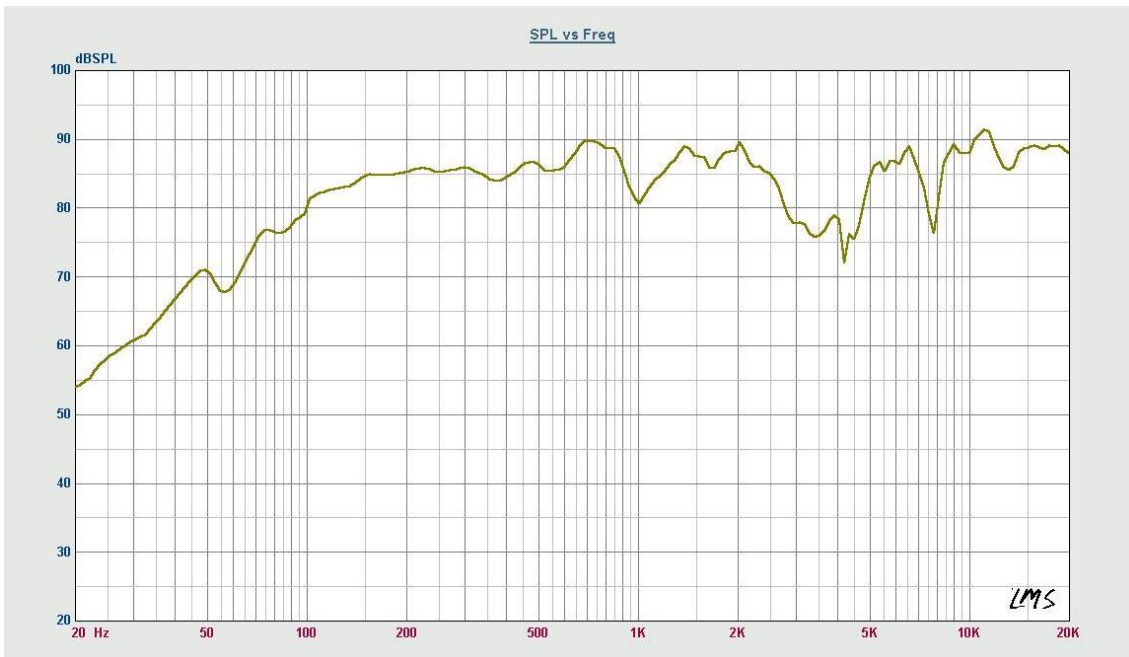

TECHNICAL DATA

eMOTUS5P	
Power	2 x 25W RMS
Impedance	8 Ω
Frequency response (± 10 dB)	85Hz – 20kHz
THD + Noise @ 1kHz Full PWR	$\leq 0.5\%$
Inputs sensitivity nom/impedance	525mV/22k Ω
CMRR - Line Bal	≥ 80 dB
Tone control response	± 14 dB
Mains voltage	115 / 230VAC (selectable)
Power consumption (pink noise, 1/8 power @ 8ohm)	≤ 10.5 W
Power consumption (pink noise, 1/3 power @ 8ohm)	≤ 23 W
Power consumption Standby	≤ 3 W
Construction	Aluminum grill, ABS cabinet
Dimensions (WxDxH)	173x185x180mm - Not including brackets; 173x248x180mm - Including brackets
Weight	4.2 kg – Not including accessories; 4.5 kg – Including accessories